

Source Four® REVOLUTION®



User Manual

For all Revolutions manufactured prior to May, 2007 (7160A1002).

Rev E
August 2008

For Revolutions manufactured May, 2007 or after (7160A1017), see Revolution User Manual 7160M1210.

The Source Four Revolution high performance automated ellipsoidal spotlight is intended for professional use only. **Read entire User Manual before using equipment.**

© Copyright 2007. Electronic Theatre Controls, Inc.
All rights reserved.
Product information and specifications subject to change.
Part Number: **7160M1200** Rev E
Released: August 2008

ACCREDITATIONS AND RECOGNITIONS (from ETL SEMKO : www.usa.etlsemko.com)

ETL SEMKO is recognized by OSHA in the U.S. as a Nationally Recognized Testing Laboratory. ETL tests to standards developed or approved by the American National Standards Institute (ANSI), Underwriters Laboratories (UL) and others. Other notable accreditations include the American Association of Laboratories Accreditations (A2LA), American National Standards Institute (ANST), International Conference of Building Officials (ICBO), and the International Electrotechnical Commission of Electrical Equipment (IECEE). ETL also has accreditations and recognitions from around the globe. Visit www.etlsemko.com/accred.html for a complete listing.

ETC, Source Four, Revolution, and QXL are registered trademarks of Electronic Theatre Controls, Inc. in the United States and other countries.

Other product and company names mentioned herein may be trademarks and/or service marks of their respective owners.

The Source Four Revolution fixture is protected by one or more of the following patents, and other pending patent applications worldwide:

US Patent # 6,628,089 B2, 6,932,491, 6,979,106, 6,902,302, 6,939,026, 6,903,531, 7,033,047 and US Design Patent #D477,885 S

USRE36,316

GB05952589

DE0592589

JP2,501772

Patents Pending

ETC intends this document, whether printed or electronic, to be provided in its entirety.

Table of Contents

Specifications	ii
Overview	1
Document Conventions	2
Safety	3
Installation	4
Power and Data cabling requirements	4
Installation procedures	5
Connections and Addressing	8
Power-up Procedure and Calibration	9
Power-down Procedure	9
Control	10
Control Values for the Standard 12-Color Gel String	11
Reset Channel	11
Timing Channels	12
Configuration	13
Removing and Replacing Modules	14
Blank Module (BM)	15
Iris Module (IM)	16
Shutter Module (SM)	17
Static Wheel Module (SWM)	18
Controlling the Static Wheel Module	18
Rotating Wheel Module (RWM)	19
Controlling the Rotating Wheel Module	20
Replacing Gobos and Filters	21
Routine Maintenance	23
Procedures	24
Scroller Cartridges and Beam Containment Devices	24
Gel Strings	25
Internal Media Frame (IMF)	27
Changing and Adjusting the Lamp	30
Adjusting Belt Tensions	32
Troubleshooting	38
LED Indicators	38
Internal Test Software	39
Photometric Data	43

Specifications

Physical

- Die cast aluminum construction
- Rugged plastic covers for field-serviceable areas
- CE compliant and ETL tested to UL 1573 standards
- High strength yoke for hanging in any orientation
- See [Dimensions and Hanging Clearances, page 6](#)
- See [Fixture Weight, page 7](#)

Electrical

- 100V-240VAC, 50/60Hz
- Electronics and internal dimmer are auto-ranging for world-wide use
- Power input via PowerCon[®] connector

Lamp

- QXL™ 750W/77V Maximum
- QXL - Quick eXchange Lamp provides one-handed replacement in seconds and disconnects lamp power automatically (Patent Pending)
- Ultra compact tungsten filament geometry contained in a Krypton/Xenon quartz envelope

Optical

- 15° - 35° zoom range
- Dual aspheric zoom lens system with deposition anti-reflective coating
- Faceted borosilicate reflector with multi-layer dichroic coating
- 95% of visible light reflected through the optical train
- 90% of infrared (I/R heat) removed from projected light beam
- Reflector secured with anti-vibration shock mounts
- Low gate and beam temperature
- Tool-free lamp centering (X/Y) and peak/flat (Z) adjustment knobs

Standard Features

- Integral Pulse Width Modulated 0-77 VAC Dimmer
- 540° Pan / 270° Tilt
- Zoom Optics
- Soft to crisp focus for gobos
- QuietDrive™ low-noise motor control technology (Patent Pending)
- Advanced cooling design for ultra-quiet operation
- Integral 20-frame color scroller with a quick-change scroller cartridge, ships with the ETC 12-color standard gel string
- Accessory slot with retainer
- Internal Media Frame for insertion of diffusion or color media into beam
- Two module bays for the tool-free addition of optional features
- Rotary switch address assignment requires no fixture power for addressing, allows access to internal test functions
- DMX512-A compliant

Optional Modules

- Auto-sensing plug-and-play modules for additional features
- Iris Module - for beam size control down to 2.5°
- Shutter Module - four blades with 90° rotation for full-function framing
- Static Wheel Module - three positions plus open for M-size glass or metal gobos and filters
- Rotating Wheel Module - three positions plus open for M-size glass or metal gobos and filters, indexes with 16-bit accuracy

Overview

Congratulations on your purchase of the Source Four® Revolution™ fixture. Source Four Revolution has been engineered for maximum performance with minimum cost.

The Source Four Revolution fixture is a modular, automated ellipsoidal reflector spotlight. The base model includes zoom optics, a color scroller with a standard gel scroll, blank modules and the internal media frame for diffusion media or color correction. Optional modules include the iris module, the shutter module, the static wheel and rotating wheel modules which can be fitted with gobos or dichroic color filters.

If you have questions about your Source Four Revolution fixture that are not answered in this manual, please contact the supplier of your ETC equipment or ETC Technical Services.

Americas

Electronic Theatre Controls Inc.
Technical Services Department
3031 Pleasant View Road
Middleton, WI 53562
800-775-4382 (USA, toll-free)
+1-608 831-4116
service@etcconnect.com

United Kingdom

Electronic Theatre Controls Ltd.
Technical Services Department
26-28 Victoria Industrial Estate
Victoria Road,
London W3 6UU England
+44 (0)20 8896 1000
service@etceurope.com

Asia

Electronic Theatre Controls Asia, Ltd.
Technical Services Department
Room 1801, 18/F
Tower 1, Phase 1 Enterprise Square
9 Sheung Yuet Road
Kowloon Bay, Kowloon, Hong Kong
+852 2799 1220
service@etcasia.com

Germany

Electronic Theatre Controls GmbH
Technical Services Department
Ohmstrasse 3
83607 Holzkirchen, Germany
+49 (80 24) 47 00-0
techserv-hoki@etcconnect.com

Please email comments about this manual to: TechComm@etcconnect.com

Document Conventions

Throughout this manual, the following are used to alert you to notes and safety notices.



Note: *Notes are helpful hints and information that is supplemental to the main text.*



CAUTION: *A Caution statement indicates situations where there may be undefined or unwanted consequences of an action, potential for data loss or an equipment problem.*



WARNING: *A Warning statement indicates situations where damage may occur, people may be harmed, or there are serious or dangerous consequences of an action.*



WARNING: ***RISK OF ELECTRIC SHOCK!** This warning statement indicates situations where there is a risk of electric shock.*

Safety

The Source Four Revolution high performance automated ellipsoidal spotlight is intended for professional use only. **Read entire User Manual before using equipment.**

Please note the following safety notices before use:



WARNING: *Note the following safety warnings before use:*

- Do not mount the Source Four Revolution fixture on or near a flammable surface.
- Use the fixture in dry locations only, where humidity does not exceed 90 percent (non-condensing). Fixture is not intended for outdoor use.
- Mount and support the fixture only by the primary suspension holes in the upper enclosure.
- Suspend the fixture from a suitable structure using a minimum of two hook clamps secured with tightened steel bolts (12 mm (1/2") Ø), washers and locking nuts.
- In addition to primary suspension, attach a safety cable (ETC Model 400SC or other approved safety cable or device) to the handles of the fixture's upper enclosure.
- Always replace the lamp if it becomes damaged or thermally deformed.
- Keep the luminaire at least 0.7m (28") away from anything it is illuminating. Objects lit at this distance or greater will not exceed 90°C (194°F) temperature from projected light.
- Disconnect the unit from power before all cleaning and maintenance.
- Maximum ambient temperature: $T_a=45^{\circ}\text{C}$ (113°F)
- Maximum exterior surface temperature: $T_{max}=270^{\circ}\text{C}$ (518°F)
- External Temperature after 5 minutes of operation: 35°C (95°F)
- External Temperature (steady state achieved): 270°C (518°F)



Installation

Power and Data cabling requirements

The Source Four Revolution fixture operates on AC power, 100-240VAC/50-60Hz, and consumes a maximum of 900 watts. You may use a circuit powered through an SCR dimmer, as long as the dimmer is set to unregulated non-dim (switched) operation.

The Source Four Revolution operates on DMX control signal. The unit is supplied with a 5-pin XLR DMX input connector and a 5-pin DMX Thru connector. DMX cables should be acceptable for DMX data transmission (not microphone cable) and should follow the standard pinout. The optional secondary data pair is not used by the Source Four Revolution fixture. On pre-2007 fixtures, termination is required after the last fixture on a DMX data line. Revolutions built in 2007 or later are equipped with self-terminating connectors.

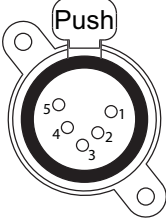
DMX512 pinout for five-pin XLR female		
	1	Common (Shield)
	2	Data -
	3	Data +
	4	not connected
	5	not connected

Installation procedures

Installing hanging hardware

The Source Four Revolution fixture's upper enclosure provides six bolt holes for installation of hanging hardware. Suspend the fixture from a suitable structure using a minimum of two hook clamps secured with tightened steel bolts (12 mm (1/2") Ø), washers and locking nuts.

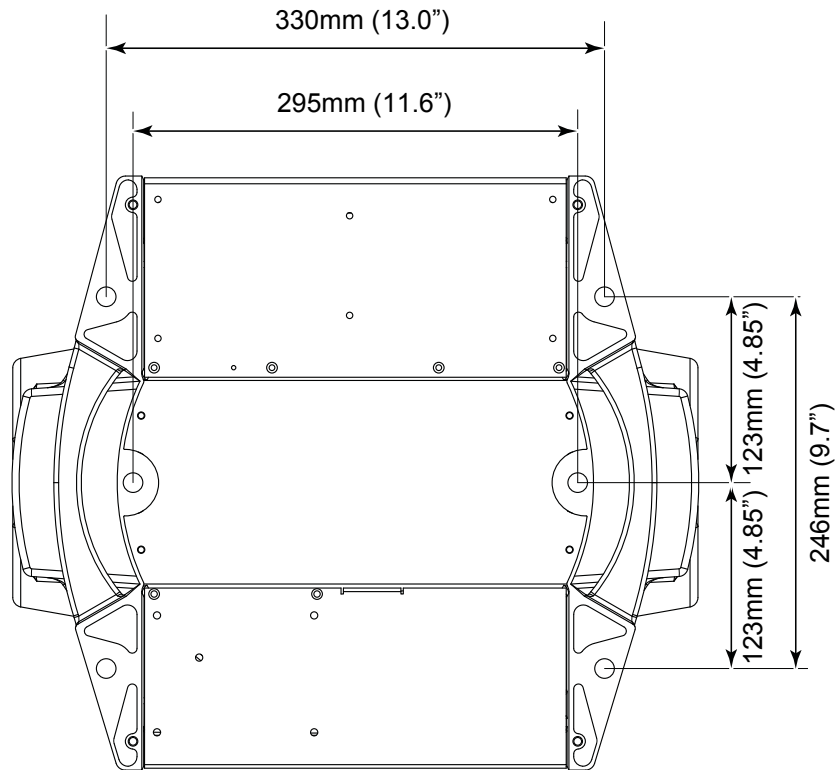

Dimensions and Hanging Clearances

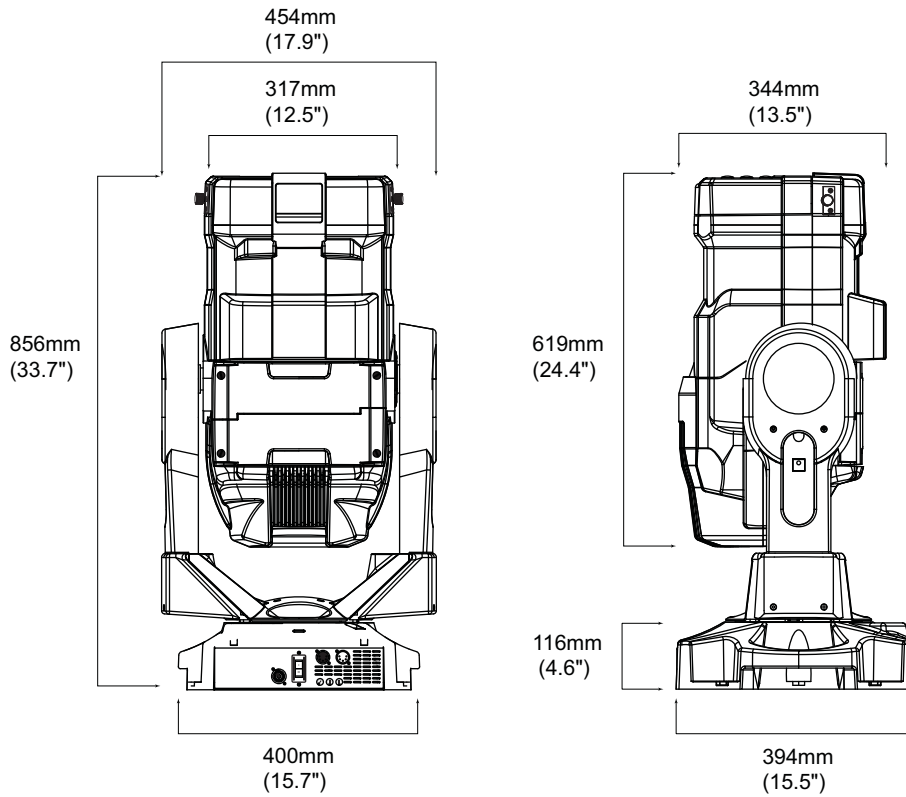

Distance between upper enclosure and pipe is variable (hanging hardware dependent).

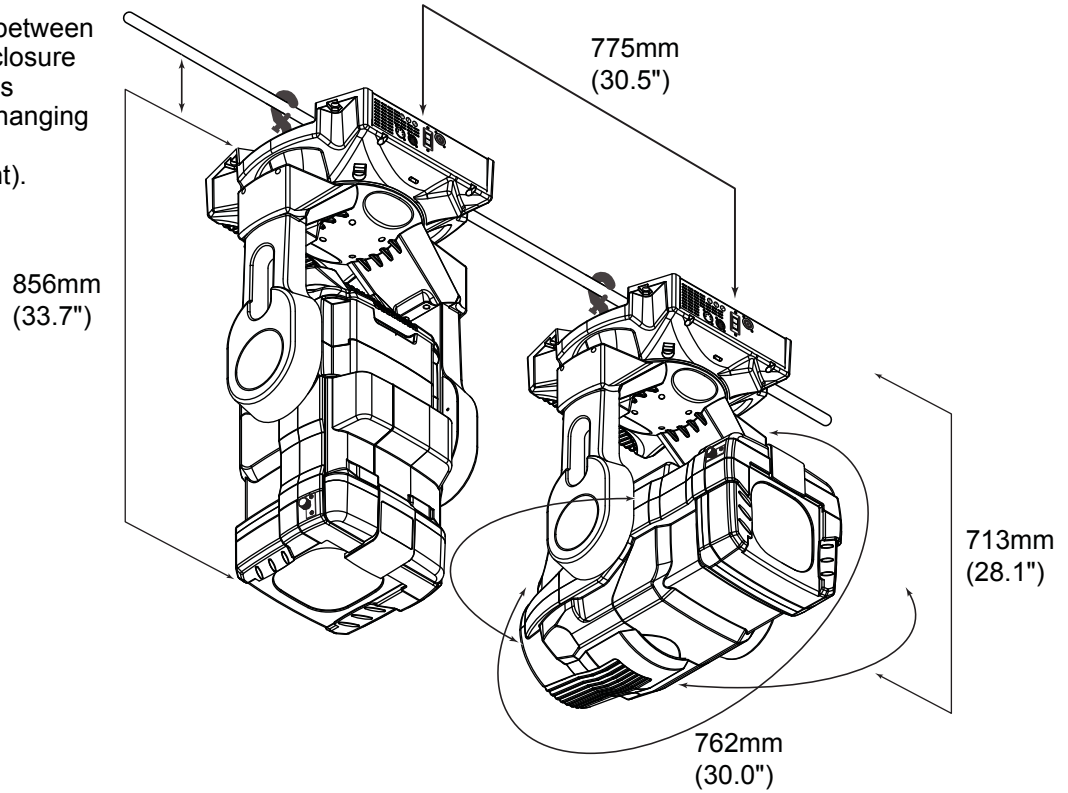

Safety Cable

The safety cable (or other approved safety device) should be secured to one of the handles on the upper enclosure, wrapped around the hanging structure (pipe), then secured to the other handle on the upper enclosure. Take care to leave as little slack as possible in the safety cable to avoid the cable catching the yoke of the fixture.

Fixture Weight

Total weight depends on how the individual fixture is configured. Use the table below to calculate the total weight of your fixture.

Device	Weight		Device	Weight	
Base Fixture	74 lb	33.6 kg	Static Wheel Module	3 lb	1.4 kg
Blank Module	1.8 lb	0.7 kg	Rotating Wheel Module	3.7 lb	1.7 kg
Iris Module	3 lb	1.4 kg	Shutter Module	10.4 lb	4.7 kg

Connections and Addressing

Connect AC input power and DMX data cables to the appropriate ports as shown below. Connect the incoming DMX data cable to the DMX Input connector. If you are daisy-chaining the data to other fixtures or DMX-controlled devices, connect the next DMX cable to the DMX Thru connector. Revolutions built prior to 2007 (Part Number 7160A1002) require that the last fixture on a DMX line be terminated with a 100Ω resistor between pins 2 and 3. Revolutions built in 2007 or after are self-terminating and do not require termination. If both types are used on the same DMX line, it is recommended that the line be terminated.

Use the three thumbwheels on the upper enclosure to set the starting address for the fixture. Addresses must be set between 1-481. The fixture will report an error if the address is set to 482 or above. See [Control, page 10](#), for channel mapping.



Note: *Revolution is a 31-channel fixture. A fixture with a starting address higher than 481 will not have control of all parameters.*

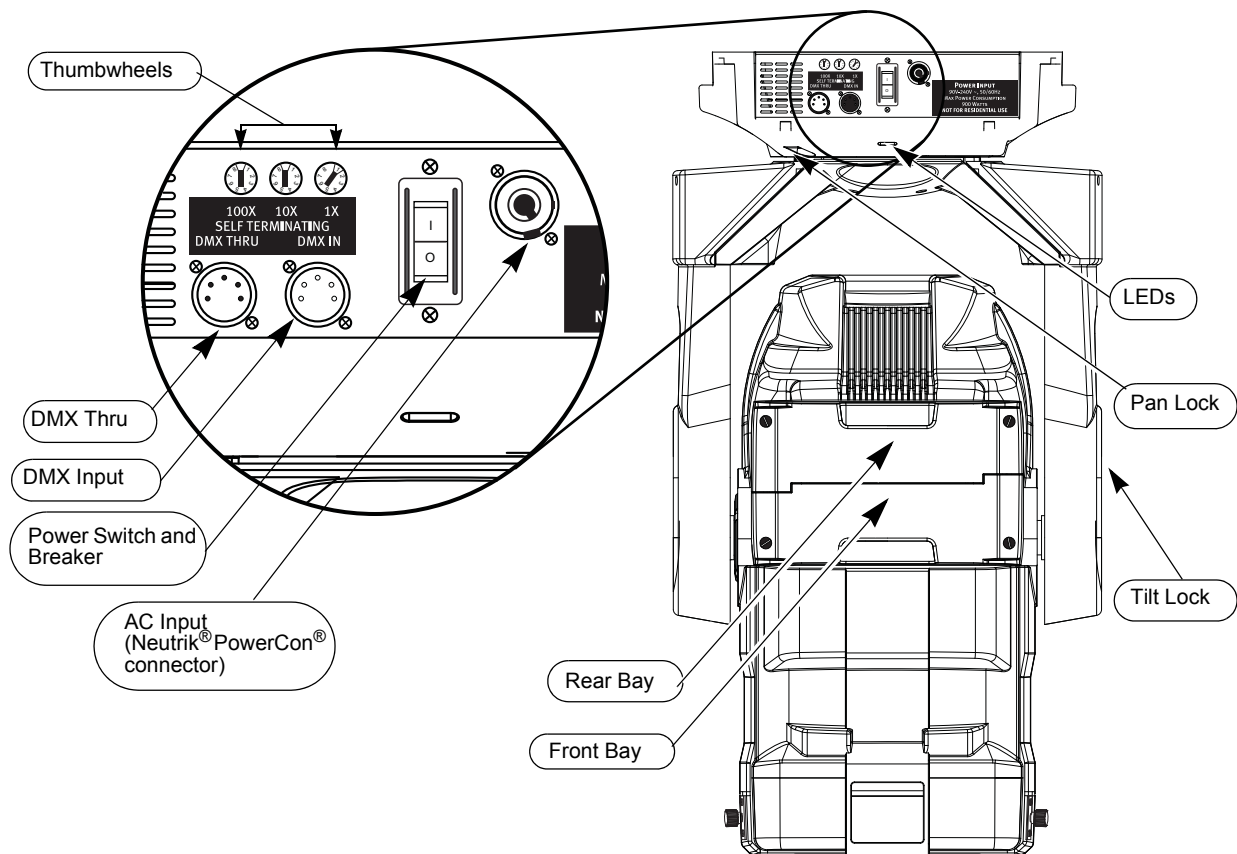

Connect the AC Input cable:

Align and insert the power connector. Twist the connector clockwise until it locks into place.

Disconnect the AC Input cable:

Slide back the locking tab, twist the connector counterclockwise and pull to unlock and disconnect the power connector.

Power-up Procedure and Calibration

Move the power switch/breaker to the “on” position to apply power to the fixture.



CAUTION: *The Source Four Revolution fixture is provided with pan and tilt locks for your convenience when working on the fixture. The pan lock is located on the upper enclosure and the tilt lock is located on the tilt side yoke leg. Ensure that the pan and tilt locks are disengaged before applying power to your fixture.*

On power-up, the fixture will perform a series of movements to calibrate its motorized functions. Once the calibration process has completed, the fixture’s motors will end in the position determined by the incoming DMX signal. If no signal is present, the fixture’s functions will rest at the position of a DMX level of zero.

Power-down Procedure

Move the power switch/breaker to the “off” position.

It is recommended that you allow the fixture to run for at least five minutes with the lamp off prior to removing power.



CAUTION: *If you are packing-up your fixture for travel, **do not pack the fixture with the yoke against the pan stop, or with the pan and tilt lock engaged.** Pan and tilt locks are provided for fixture maintenance only and are not to be engaged during shipment. This will damage the end stop(s) and will prevent your fixture from calibrating correctly in the future.*

Control

The Source Four Revolution fixture can take as few as 14 and up to 31 DMX channels to operate. The table below describes the order and function of each address, as well as which parameters are affected by the timing channels.

Timing channels give you the option to have the fixture calculate parameter movement over time, instead of using DMX fades and cue timing. Using timing channels may produce smoother movement of parameters (see [Timing Channels, page 12](#)).

Fixture personalities can be found at ETC's website: www.etcconnect.com

DMX	Base Unit	Base + Modules	Base + Framing	Timing Channel
1	Intensity	Intensity	Intensity	
2	Pan (Coarse)	Pan (Coarse)	Pan (Coarse)	F
3	Pan (Fine)	Pan (Fine)	Pan (Fine)	F
4	Tilt (Coarse)	Tilt (Coarse)	Tilt (Coarse)	F
5	Tilt (Fine)	Tilt (Fine)	Tilt (Fine)	F
6	Internal Media Frame	Internal Media Frame	Internal Media Frame	
7	Focus	Focus	Focus	B
8	Zoom	Zoom	Zoom	B
9	Focus Timing (F)	Focus Timing (F)	Focus Timing (F)	
10	Color Timing (C)	Color Timing (C)	Color Timing (C)	
11	Beam Timing (B)	Beam Timing (B)	Beam Timing (B)	
12	Reset	Reset	Reset	
13	Gel Scroller	Gel Scroller	Gel Scroller	C
14	Fan Speed Control	Fan Speed Control	Fan Speed Control	
15		Iris	Iris	B
16		Front Bay Wheel Position	Front Bay Wheel Position	B
17		Front Bay Wheel Function	Front Bay Wheel Function	B
18		Front Bay Wheel Index/ Rotation (Coarse)	Front Bay Wheel Index/ Rotation (Coarse)	B
19		Front Bay Wheel Index/ Rotation (Fine)	Front Bay Wheel Index/ Rotation (Fine)	B
20		Rear Bay Wheel Position	Reserved	B
21		Rear Bay Wheel Function*	Reserved	B
22		Rear Bay Wheel Index/ Rotation (Coarse) ^a	Reserved	B
23		Rear Bay Wheel Index/ Rotation (Fine) ^a	Reserved	B
24			#1 Shutter In	B
25			#1 Shutter Rotate	B
26			#2 Shutter In	B
27			#2 Shutter Rotate	B
28			#3 Shutter In	B
29			#3 Shutter Rotate	B
30			#4 Shutter In	B
31			#4 Shutter Rotate	B

a) Prolonged use of the Rotating Wheel Module in the Rear Bay may cause the belt within the module to degrade. To ensure peak performance of the RWM, use it in the Front Bay.

Control Values for the Standard 12-Color Gel String

Frame	Gel Number ^a	Gel Name	Percent Start	Percent End	Percent Center Frame	DMX Start	DMX End	DMX Center Frame
0 (Leader)	—	Open White	0%	7%	3%	0	17	9
1	R02	Bastard Amber	7%	14%	11%	18	36	27
2	R05	Rose Tint	15%	21%	18%	37	54	46
3	R09	Pale Amber Gold	22%	28%	25%	55	72	64
4	R54	Special Lavender	29%	35%	32%	73	90	82
5	R357	Royal Lavender	36%	43%	39%	91	109	100
6	R36	Medium Pink	43%	50%	46%	110	127	119
7	R25	Orange Red	50%	57%	54%	128	145	137
8	L203	1/4 C.T. Blue	57%	64%	61%	146	164	155
9	L201	Full C.T. Blue	65%	71%	68%	165	182	174
10	R68	Sky Blue	72%	78%	75%	183	200	192
11	R88	Light Green	79%	85%	82%	201	218	210
12	L-HT115	Peacock Blue	86%	93%	89%	219	237	228
13 (Trailer)	—	Open White	93%	100%	97%	238	255	247

a) R = Roscolux and Rosco Supergel numbers, L = Lee.

Reset Channel

To use the Reset Channel (Channel 12), set the channel to one of the levels shown below for three seconds, then set the channel to 0% without timing or fading. The fixture will recalibrate the functions associated with the reset level and return to the settings provided by the incoming DMX data.

Reset Function	DMX Percent	DMX Decimal
Reset entire fixture	75	185-190
Reset scroller and lenses only	60	147-152
Reset Pan and Tilt only	50	126-129
Reset Front Module only	40	97-102
Reset Rear Module only	30	72-77

Timing Channels

Three timing channels are provided: Focus Timing (Channel 9), Color Timing (Channel 10), and Beam Timing (Channel 11). These channels can be used to communicate the desired duration of a movement at the same time you communicate the destination of the movement. The instructions below describe the general method of using a timing channel. Specific instructions for recording cue fade times or part cues can be found in your control console's user manual.

Using timing channels to set parameter timing:

- Step 1: Determine which timing channel controls the parameters you want to affect (see [Control, page 10](#)).
- Step 2: Set the timing channel to the appropriate value. Each step of DMX equals one second of time. Percent-based consoles will have a granularity of ~2.5 seconds per step. The maximum timing value is 4 minutes 15 seconds.
- Step 3: Record the parameter channels and their corresponding timing channel into a cue or cue part with zero fade timing. Avoid placing timing channel moves within a cue or cue part that contains a fade time other than zero. Fading a timing channel and its corresponding parameter channels can create unexpected luminaire behavior.
- Step 4: Repeat for other parameter channels and timing channels as needed.

Fan Speed Control Channel

The Fan Speed Control Channel (Channel 14) allows fan speed control for quieter fixture operation. As long as this channel is at 0%, all fans will run at full speed for maximum cooling. Setting this channel at incrementally higher values lowers the fan speed incrementally.

For example, 25% = 75% fan speed, 50% = 50% fan speed, 75% = 25% fan speed, and so on. Setting this channel at 100% will turn the fans off completely for silent operation.

Temperature sensors in the Revolution sense if fans are required to keep the fixture from an over-temperature condition. These sensors override the fan speed channel and cause the fans to operate to prevent over-heating, regardless of the channel setting.

For longer gel string life—especially saturated colors—keep the fan speed as high as possible, that is, a lower value for channel 14.

Using Focus Timing for Console Response Option

Setting the Focus Timing Channel (Channel 9) at 100% provides more responsive manual control of Revolution parameters. Remember to restore this channel to 0% (or the desired timing speed value less than 100%) for smoothest cue playback operation.



Note: *Playback of cues with the Focus Channel set at 100% may result in less than satisfactory luminaire movement.*

Configuration

With Source Four Revolution, you decide how to configure your light. The standard base unit provides pan, tilt, beam-edge change, 15-35° zoom range, two Blank Modules, Internal Media Frame, integrated color scrolling, and on-board dimming. The unit's module bays can be filled with any of the modules described below.

Blank Module (BM)

- Space for one static metal M-sized gobo

Iris Module (IM)

- 18-leaf iris
- Smooth operation
- Simple, repeatable beam-size control
- On-board auto-sensing electronics

Shutter Module (SM)

- Multi-plane shutters for flexible beam shaping
- All shutters have +/- 45° rotation (total range of motion = 90°)
- On-board auto-sensing electronics

Static Wheel Module (SWM)

- Four positions, typically setup as three positions plus open
- Gobos or dichroic color filters
- Uses M-sized gobos, glass or metal
- On-board auto-sensing electronics

Rotating Wheel Module (RWM)

- Three positions, plus open
- Rotating, indexable gobos
- Uses M-sized gobos, glass or metal
- On-board auto-sensing electronics

Module/Bay Compatibility

Module Type	Front Bay	Rear Bay
Blank Module (BM)	Yes	Yes
Iris Module (IM)	Yes	Yes
Shutter Module (SM)	No	Yes
Static Wheel Module (SWM)	Yes	Yes
Rotating Wheel Module (RWM)	Recommended for best performance	Not Recommended ^a

a) Prolonged use of the Rotating Wheel Module in the Rear Bay may cause the belt within the module to degrade. To ensure peak performance of the RWM, use it in the Front Bay.

Removing and Replacing Modules

Each module is secured with two thumbscrews. See the diagram below for bay designation.

Remove a module:

Step 1: Power-down the fixture. See [Power-down Procedure, page 9](#).



CAUTION: *Screws securing the modules may be hot if the fixture has recently been lit.*

Step 2: Loosen the two screws securing the module by turning them to the left (counterclockwise).

Step 3: Pull the module gently out of the head of the fixture.

Insert a module:

Step 1: Align the module in the selected bay with the interface connector closest to the center bay divider.

Step 2: Guide the module gently into the bay making certain that the guide posts of the module housing are properly aligned with the accommodating hole in the fixture frame. Ensure that the module seats on the control card.

Step 3: Tighten the screws securing the module by turning them to the right (clockwise). **Ensure that the screws are tightened completely.**



CAUTION: *Prolonged use of the Rotating Wheel Module in the rear bay may cause the belt within the module to degrade. To ensure peak performance of the RWM, use it in the Front Bay.*

*Shutter Modules **must** be placed only in the rear bay. Shutter module installation also must include mounting the counterweight frame that came with the revolution in the front of the unit. See [Shutter Module \(SM\), page 17](#).*

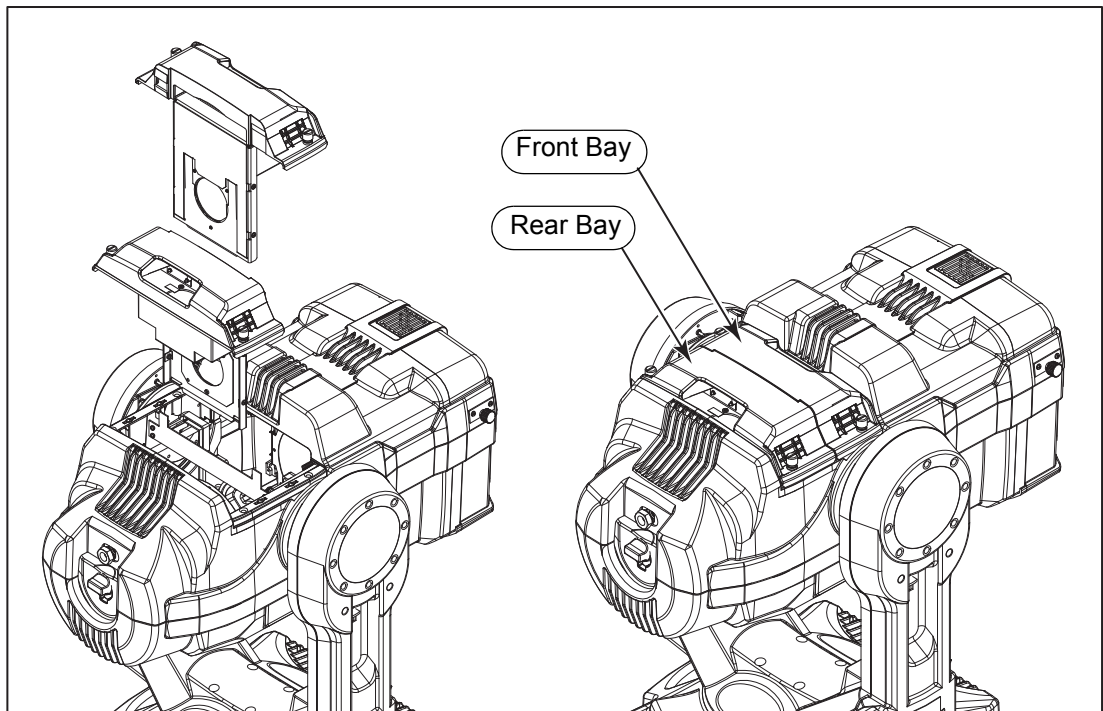

Blank Module (BM)

The Blank Module is used to fill an empty module bay, and can be used to hold a static M-Size metal gobo, if needed.

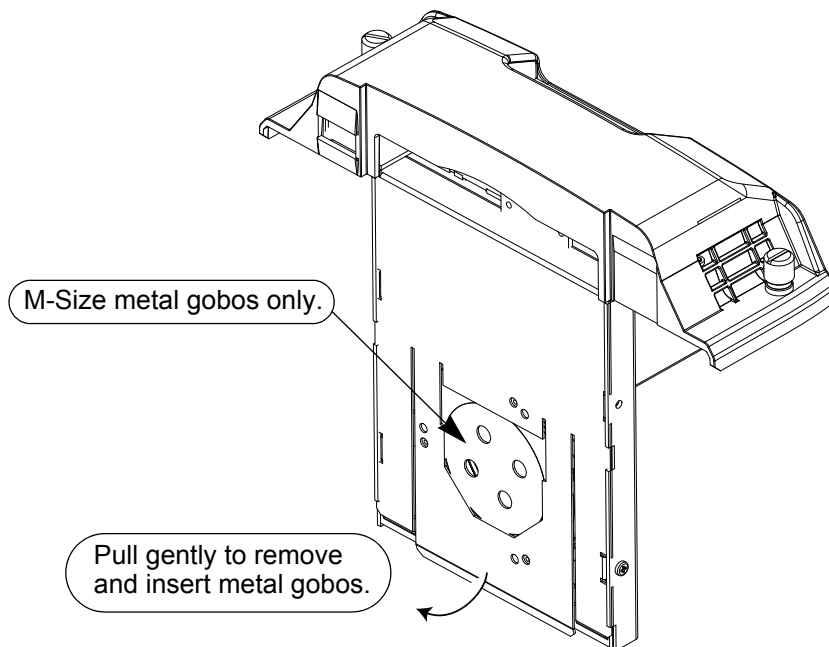

Iris Module (IM)

The Iris Module contains an 18-leaf iris and can be placed in either module bay.

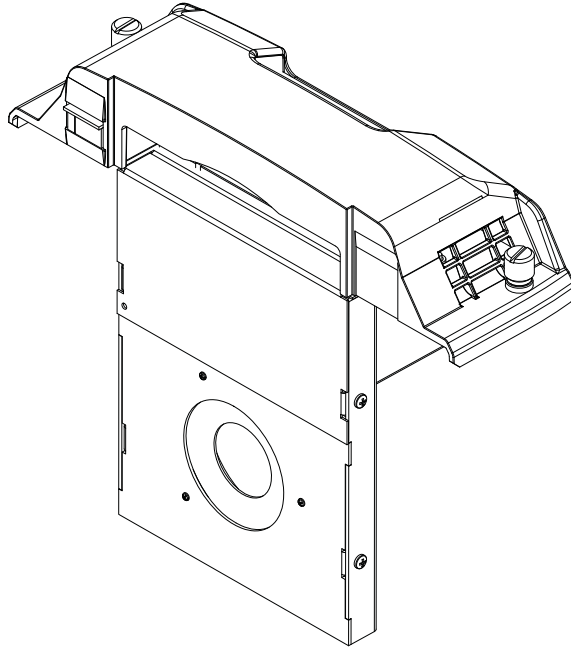

Shutter Module (SM)

The Shutter Module contains a four-blade shutter mechanism. Each shutter can be rotated $\pm 45^\circ$ (total range of motion = 90°).



CAUTION: *The Shutter Module must be placed in the Rear Bay. It will not operate in the Front Bay.*

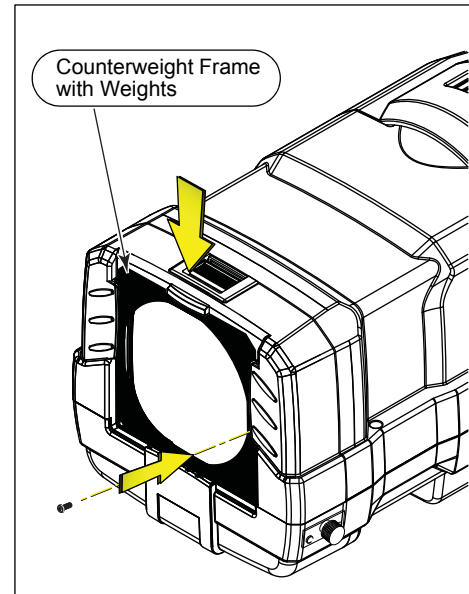
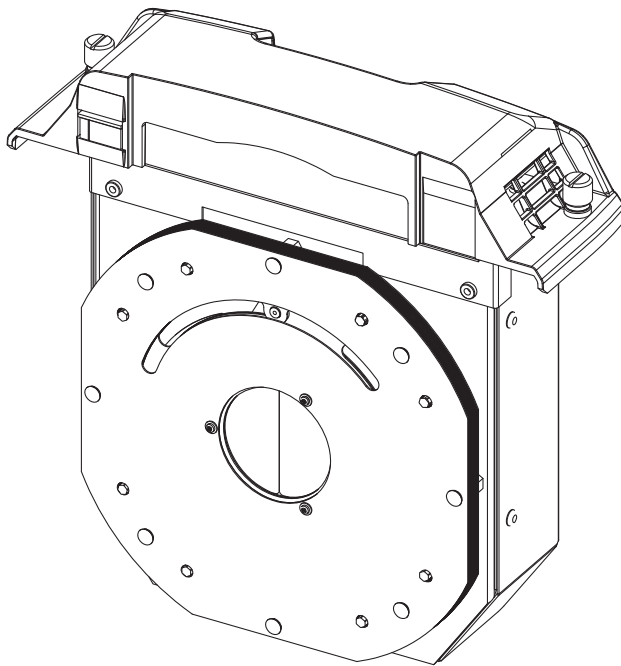

A counterweight frame insert is included to offset the weight of an installed shutter module. When using the shutter module in your Revolution fixture, you must also insert the counterweight frame into the gel frame slot at the front of the color scroller. This will ensure proper pan and tilt function.

After the counterweight is inserted, secure it in place with the top latch (see [page 24](#)).

If desired, a standard (1.1 lb/0.5 kg) tophat can be substituted for the counterweight frame insert.



WARNING: *The counterweight must be secured to the fixture with the provided screw.*



CAUTION: *You must use a counterweight frame insert when using a shutter module. Failure to do so may result in pan and tilt malfunction.*

Static Wheel Module (SWM)

The Static Wheel Module contains a wheel with three positions for static M-size steel or glass gobos or dichroic color filters and an open position. If desired, the open position can be used to hold a fourth gobo or filter.



CAUTION: *To prevent cracking of glass gobos and for best image contrast, the silver reflective surface of the gobo must face the lamp and the black surface of the gobo must face the lenses.*

Controlling the Static Wheel Module

The Static Wheel Module uses an 8-bit channel to select the frame. Only full frames can be produced. Use the table below to set the Wheel Position channel.

Wheel Position Channel	DMX Percent	DMX Decimal
Open (Position 0)	0-5%	0-13
Position 1	6-10%	14-26
Position 2	11-15%	27-39
Position 3	16-20%	40-50
Reserved (Position 3)	21-100%	51-255

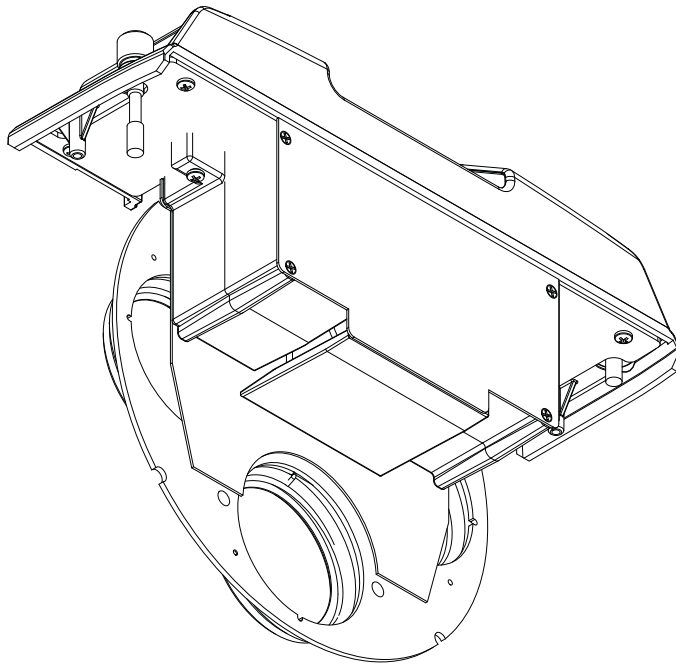

Rotating Wheel Module (RWM)

The Rotating Wheel Module contains a wheel with three rotating/indexing positions for static M-size steel or glass gobos or dichroic color filters and an open position.



CAUTION: *To prevent cracking of glass gobos and for best image contrast, the silver reflective surface of the gobo must face the lamp and the black surface of the gobo must face the lenses. Prolonged use of the Rotating Wheel Module in the Rear Bay may cause the belt within the module to degrade. To ensure peak performance of the RWM, use it in the Front Bay.*

Controlling the Rotating Wheel Module

The Rotating Wheel Module uses two 8-bit channels to select the frame and determine the index or rotation function of that frame, and a 16-bit channel to determine the index position or rotation speed of that frame.

Wheel Position Channel	DMX Percent	DMX Decimal
Open	0-5%	0-13
Position 1	6-10%	14-26
Position 2	11-15%	27-39
Position 3	16-20%	40-50
Reserved (Position 3)	21-100%	51-255

Wheel Function Channel	DMX Percent	DMX Decimal
Index	0-5%	0-13
Rotate >>	6-10%	14-26
Rotate <<	11-15%	27-39
Reserved	16-100%	40-255

Wheel Index/Rotation Channel	DMX Percent	DMX Decimal
If Indexing, use this 16-bit channel to align the image	0-100%	0-255
If Rotating, use this 16-bit channel to set rotation speed (0-30 RPM)	0-100%	0-255

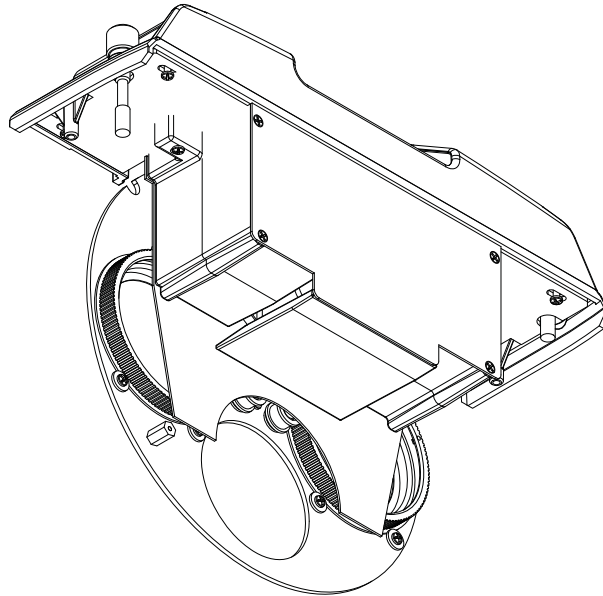

Replacing Gobos and Filters

The Static Wheel Module and the Rotating Wheel Module both use the same gobo/filter retention method. In each case, the gobo/filter is secured with a spring.

Replace a gobo/filter:

Step 1: Power-down the fixture. See [Power-down Procedure, page 9](#).

Step 2: Remove the module from the fixture. See [Removing and Replacing Modules, page 14](#).



CAUTION: *Screws securing the modules, and the wheels themselves, may be hot if the fixture has recently been lit. Allow the module to cool before installing gobos or filters.*

Step 3: Remove the spring securing the gobo/filter you want to replace or install. Use the diagram below to determine the frame numbers on each wheel. In newer modules, notches have been cut into the wheel close to the positions, indicating the position's number. In older modules, these notches do not exist. If you have an older module, use the diagram below to find the position number.

- Magnets are found in the alignment holes for frame #3 in each wheel. The Rotating Wheel Module has two magnets, one for calibrating the wheel position, and one for calibrating the index position of the frames.

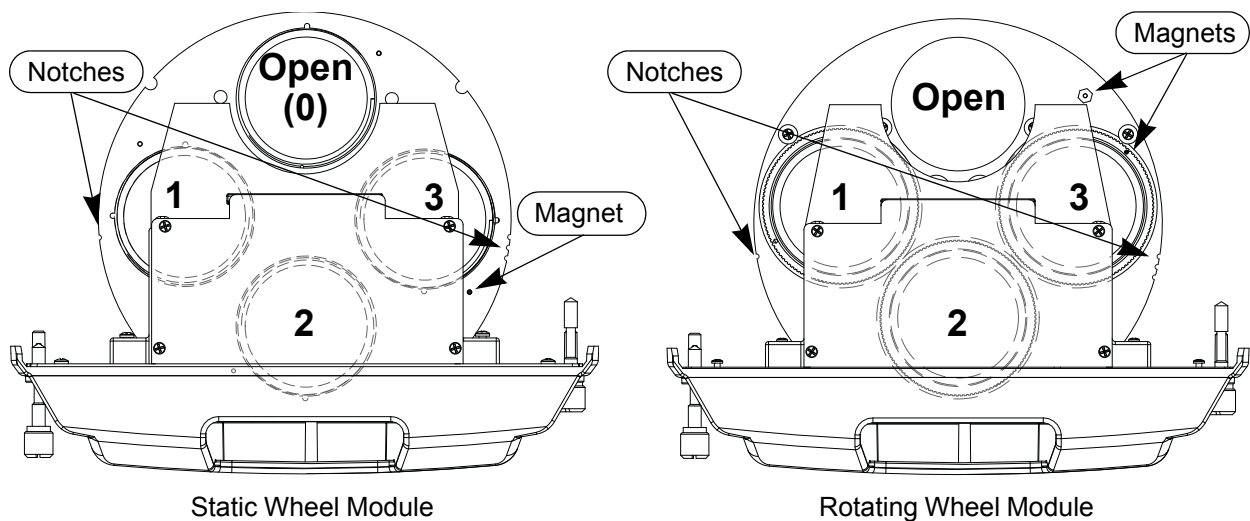

Static Wheel Module

Rotating Wheel Module

Step 4: Remove the gobo/filter, if present.

Step 5: Insert the new gobo/filter in the frame. Use the hole in or near the frame (see below for alignment hole locations) to align your gobo, if required.



CAUTION: *To prevent cracking of glass gobos and for best image contrast, the silver reflective surface of the gobo must face the lamp and the black surface of the gobo must face the lenses. Prolonged use of the Rotating Wheel Module in the Rear Bay may cause the belt within the module to degrade. To ensure peak performance of the RWM, use it in the Front Bay.*

- Step 6: Insert the spring into the frame. Ensure that the gobo/filter is held securely in place and that the spring is fully inserted in the frame.
- Step 7: Reinsert the module into the fixture and tighten the screws securing the module.

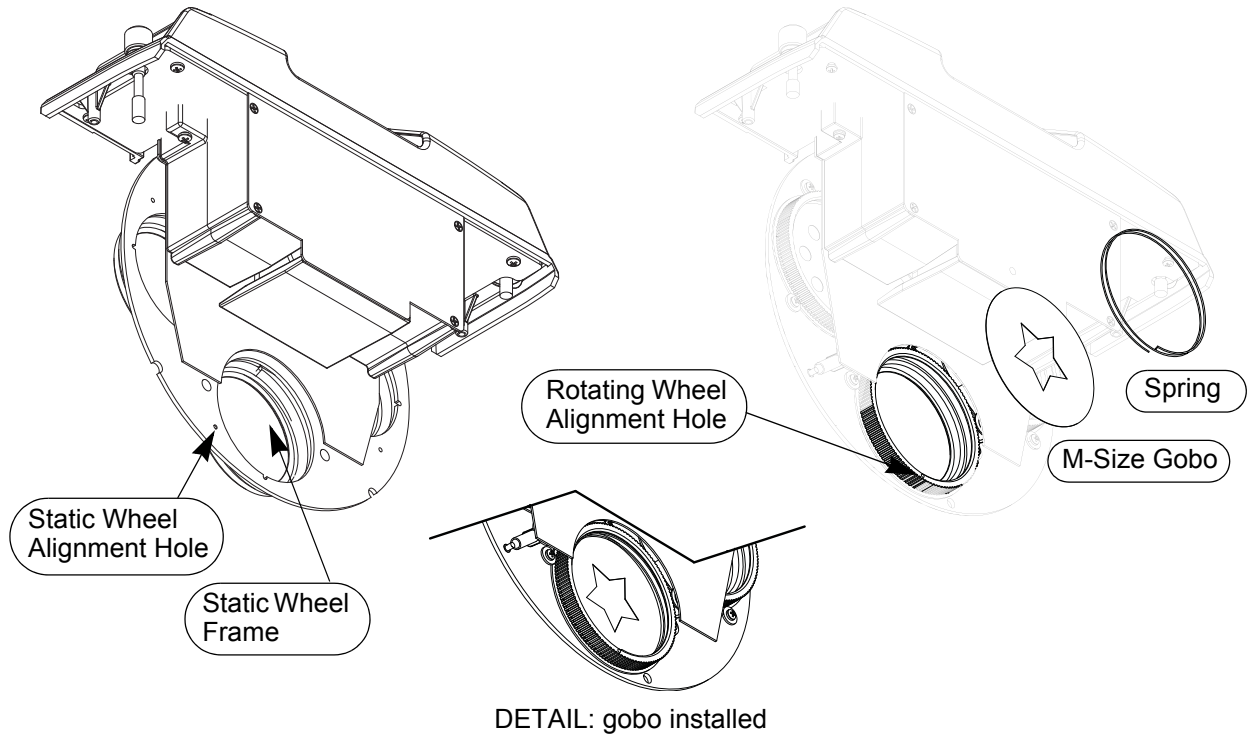

Routine Maintenance

To ensure optimum performance of your Source Four Revolution fixture, you should perform the following inspections and cleanings at least once a year. You may need to inspect or clean the fixture more often, depending on the type and amount of use your fixture experiences during the year.



CAUTION: *NEVER spray liquids into the fixture.*

NEVER spray compressed air into a fixture that is powered-up.

ALWAYS remove the lamp prior to cleaning the reflector.

- Open the fixture and clean out any dust and debris. All components can be cleaned using compressed, oil-free air or a soft, lint-free cloth. No liquids of any type should be used to clean the interior of the fixture.
- Inspect all modules for wear and, if necessary, clean using compressed, oil-free air or a soft, lint-free cloth.
- Power up the unit with the covers removed and watch for all of the components to move freely upon fixture calibration.
- Inspect gel string for wear and replace as needed. See [Gel Strings, page 25](#).
- Inspect Internal Media Frame media and replace as needed. See [Internal Media Frame \(IMF\), page 27](#).
- Inspect gobos for wear and cracking. Replace as needed.
- Inspect both lenses and the reflector for cleanliness.
To clean the lenses, dampen a soft, lint-free cloth with vinegar or household ammonia and gently wipe each lens surface.
To clean the reflector, remove the lamp, dampen a soft, lint-free cloth with alcohol or distilled water and gently wipe the reflector.
- Adjust the tension of the various belt drive mechanisms. See [Adjusting Belt Tensions, page 32](#).



WARNING: *Regularly check to make sure all modules are fully seated in the module bays. Also ensure that the module thumbscrews are fully finger-tightened.*

Procedures

Scroller Cartridges and Beam Containment Devices

The Source Four Revolution fixture is provided with a removable scroller cartridge. You can swap whole cartridges, or you can replace only the gel string within the cartridge. The Scroller Cartridge also contains an accessory slot that may be used for a single standard 7.5" color frame or a beam containment device such as a top hat, half-hat or egg-crate. An attachment point is provided on the underside of the fixture head for safety tethers on installed beam containment devices.



CAUTION: *To ensure optimum pan/tilt movement, beam containment devices must not exceed .45kg (1 pound) of weight at a center of mass 76mm (3") from the front of the fixture. Most standard tophats, half-hats, and egg-crates should fall into this acceptable category. Barndoors and other heavy accessories or devices should be avoided.*

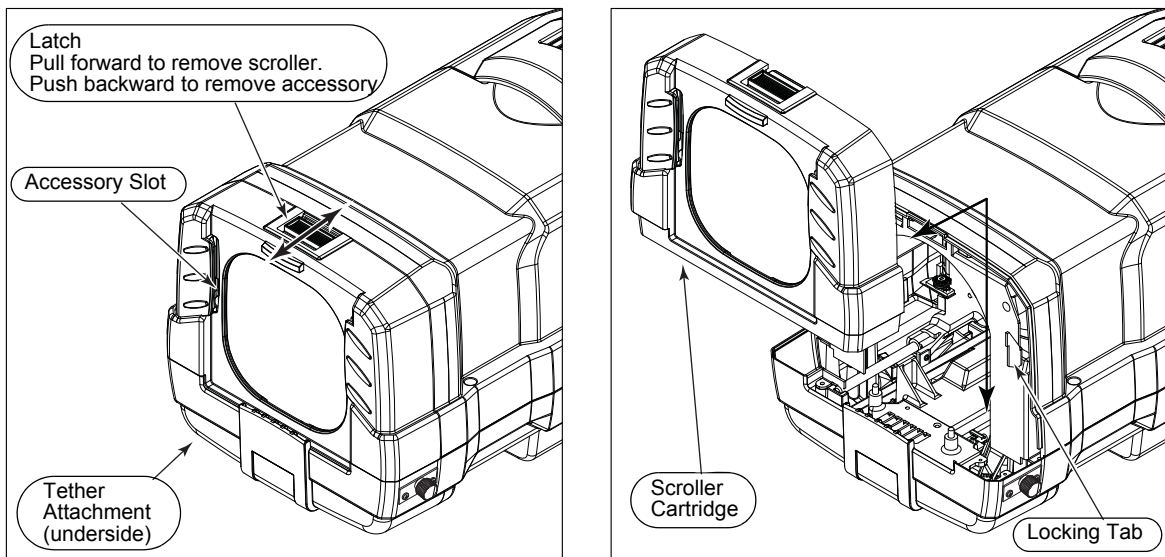

Removing and replacing the Scroller Cartridge:

- Step 1: Pull the latch on top of the scroller cartridge forward and pull the scroller up out of the head. The gel string is held in tension and may roll back after being released from the head.
- Step 2: To insert a scroller cartridge, align the metal tabs on the fixture with the slots on the back of the scroller cartridge and slide the cartridge back onto the tabs.
- Step 3: Pull the latch on the top of the cartridge forward and press the cartridge down into place.
- Step 4: Release the latch. It is spring-loaded and will slide back into the locked position upon release.
- Step 5: Recalibrate the fixture after replacing the scroller cartridge.

Installing or removing beam containment devices and color frames:

- Step 1: Push the latch on top of the scroller cartridge toward the back of the fixture head to clear the accessory slot on the front of the cartridge.
- Step 2: Insert or remove the beam containment device or color frame.
- Step 3: Release the latch. It is spring-loaded and will slide back into the locked position upon release. If the safety tether is present, attach it to the installed beam containment device.

Gel Strings

You can change the gel string in your fixture. Replacement strings must have a minimum of 2 frames or a maximum of 20 frames of gel media. If you are going to make or purchase your own gel strings, follow the specifications below to ensure proper performance.

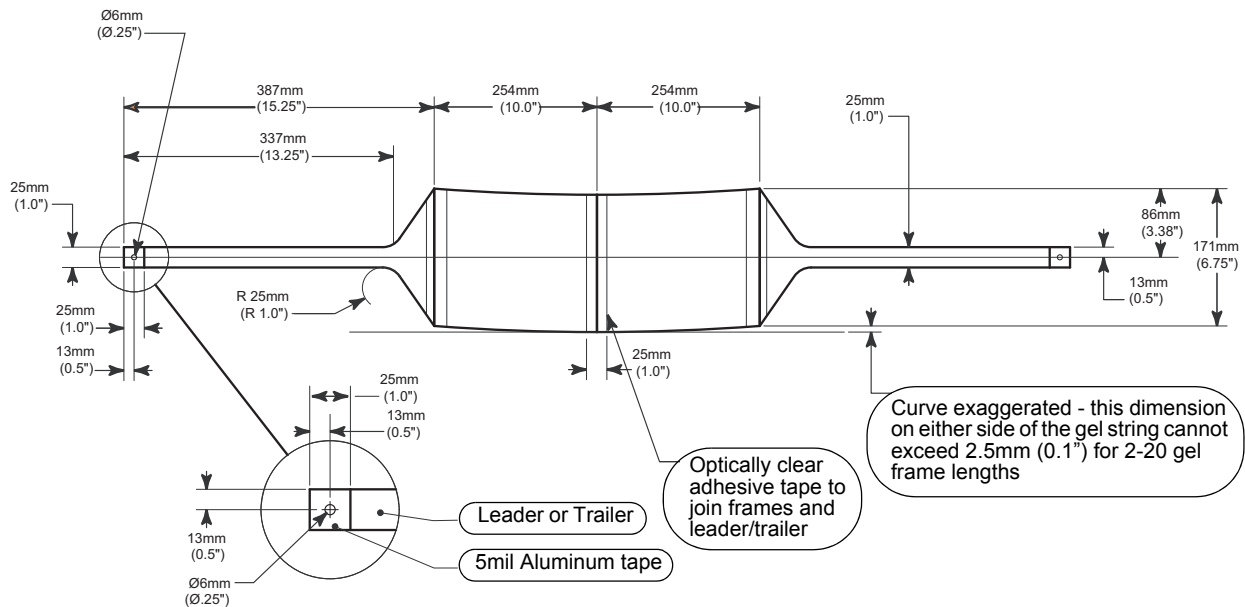

Replacing the gel string:

- Step 1: Remove the scroller cartridge from the fixture by pulling the latch forward and pulling the cartridge up out of the head. The gel string is held in tension and may roll back after being released from the head.
- Step 2: Place the cartridge on a flat surface and, if necessary, wind the gel string back onto the right spool.

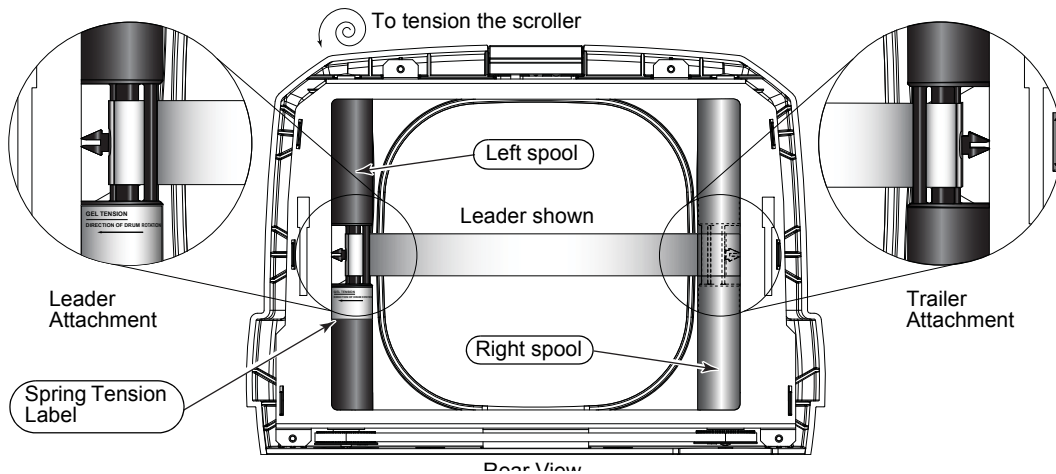

- Step 3: When the attachment tab on the left spool is revealed at the end of the leader, release the tab from the attachment point.
- Step 4: Carefully roll up the gel string. When the gel string is rolled up, the trailer attachment point on the right spool is revealed.
- Step 5: Detach trailer from the right spool and remove the gel string.
- Step 6: Attach the replacement gel string's trailer to the right spool by feeding the attachment tab down through the bar/slot and around onto the attachment point.
- Step 7: Roll the gel string tightly onto the right spool. Leave enough of the scroll unrolled to allow you to attach the leader to the left spool. Keep tension on the scroll.
- Step 8: With your other hand, while placing your thumb on the bar and slot portion of the left spool, spin the spool away from the center of the cartridge until the attachment point is facing up. Then spin the spool as listed on the spring tension label (located on the left spool) to generate the proper tension in the spring. Continue spinning the spool about 1/4 turn until the bar/slot is visible and facing the center of the scroller cartridge, as shown above.
- Step 9: Feed the end of the leader up through the bar/slot and over onto the attachment point.
- Step 10: When the leader is attached to the left spool, let go of the spools. The gel scroll should spool a number of frames onto the left spool and then settle.
- Step 11: Reset the fixture to calibrate and ensure proper performance of the scroller.

Internal Media Frame (IMF)

The internal media frame is designed to hold two pieces of gel within two semi-circular removable frames. Performance of the gel in the internal media frame will vary with frequency of use, materials and transmission properties of the gel. Some gels will perform better than others.

It is possible for the gel in the internal media frame to warp or wear out, which can affect the operation of the internal media frame mechanism or cause unwanted noise. If this occurs, replace the gel. If the IMF is making noise, see [Adjusting the IMF, page 28](#).

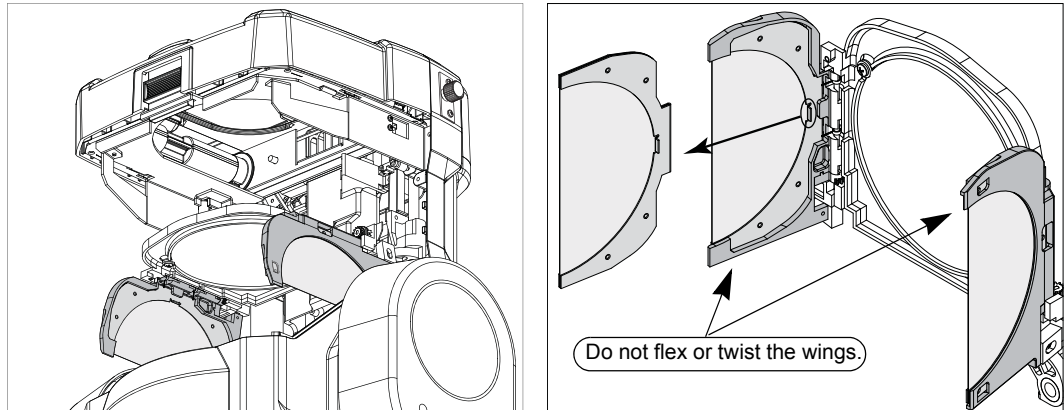

Changing the gel in the internal media frame:

- Step 1: Power-down the fixture. See [Power-down Procedure, page 9](#).
- Step 2: Lock the fixture head and yoke in a convenient position using the pan and tilt locks.
- Step 3: Remove the scroller cartridge. Pull the latch on top of the scroller cartridge forward and pull the scroller up out of the head. The gel string is held in tension and may roll back after being released from the head.
- Step 4: Remove the head cover by loosening the two captured screws holding it in place and lifting the cover off the head.
- Step 5: Slowly pull the front lens forward until the internal media frame is accessible, and open, if necessary.
- Step 6: Remove the frames from each side of the internal media frame mechanism by pulling the tab straight out of each wing. Do not flex or twist the wings.

- Step 7: Remove the old media and replace the media in each frame. Trim the media to the shape of the frame. Trim the center edge carefully so that it is straight and without nicks or extra bits of gel that could catch when the two wings close together.
- Step 8: Insert the frames back into the wings of the internal media frame mechanism until they “click” into place, ensuring they are fully seated. The frames are identical and may be installed into either wing.
- Step 9: Replace the head cover and the scroller cartridge.
- Step 10: Unlock the yoke.

Adjusting the IMF

The IMF is designed to operate quietly. If it becomes noisy or does not open and close properly, you can adjust it. The IMF is opened and closed by a pair of pawls that contact the door tabs. Both the pawl spring tension and the door tabs can be adjusted. If the spring has too much tension, the pawl will make a "snapping" noise. If the spring is too loose, the pawl will not engage the IMF door tab properly. If the door tabs are not adjusted properly, they will obstruct the pawls or prevent the IMF from opening and closing.



Note: *Prior to adjusting the IMF, make sure the front lens belt is properly adjusted. See [Adjusting the front lens belt](#); page 36.*

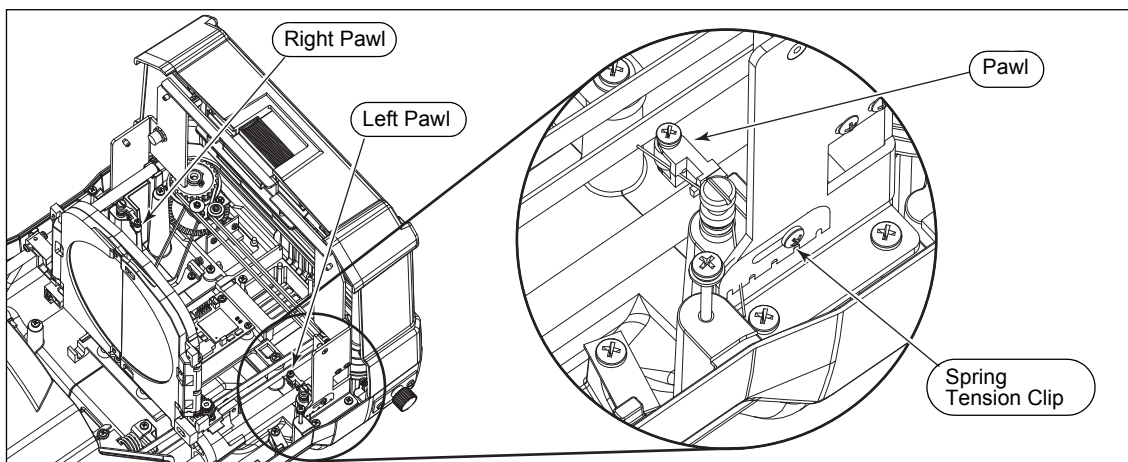

Adjusting the IMF pawls:

- Step 1: Power-down the fixture. See [Power-down Procedure](#), page 9.
- Step 2: Lock the fixture head and yoke in a convenient position using the pan and tilt locks.
- Step 3: Remove the head cover by loosening the two captured screws holding it in place and lifting the cover off the head.
- Step 4: Using both hands, move the IMF assembly back away from the front of the fixture.
- Step 5: Loosen the spring tension clip screw so that the clip moves freely.
- Step 6: Move the clip forward or backward and flip the pawl with your other hand. If the pawl makes a snapping noise, loosen the spring tension by moving the spring clip towards the front of the fixture. If the pawl does not close completely so that it does not engage the IMF doors, move the clip toward the rear of the fixture.



Note: *If the spring clip does not allow enough movement, move the spring to the next notch in the clip.*

- Step 7: When the pawl operates fairly quietly, tighten the spring tension clip screw.
- Step 8: Adjust the other pawl if needed.
- Step 9: Test the IMF operation by turning the IMF motor counter-clockwise by hand to move the IMF forward. The IMF should close and as you continue turning the motor, the doors should open.

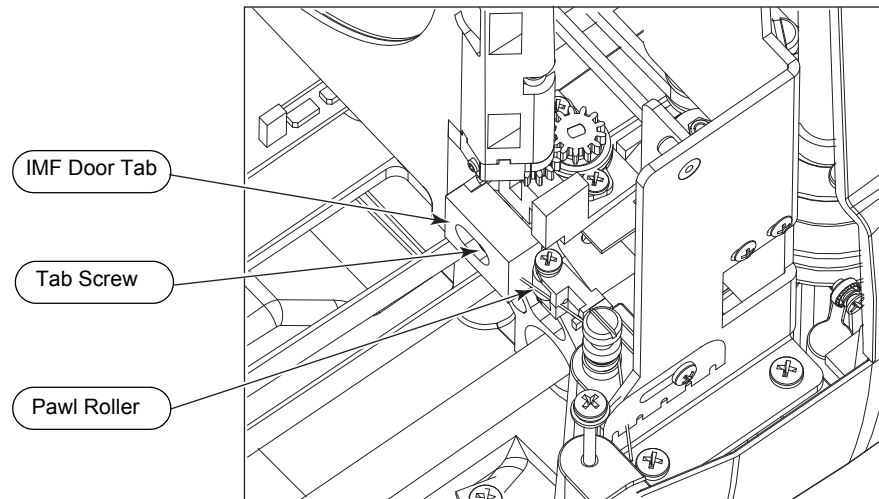

Left IMF door shown

Adjusting the IMF door tabs:

- Step 1: Make sure the pawls are adjusted properly. If not, see [Adjusting the IMF pawls](#), page 28.
- Step 2: Close the IMF doors and move them so that the door tabs are in line with the pawls.
- Step 3: Loosen the left door adjustment tab screw and move the tab so that it just nearly contacts the pawl roller. You should be able to slip a piece of paper easily between the pawl and roller.
- Step 4: Adjust the right tab so that it has slightly more clearance (approximately 1.6 mm (1/16")).
- Step 5: Check the operation of the IMF operation by turning the IMF motor by hand counter-clockwise to move the IMF forward. The IMF should close and as you continue turning the motor, the doors should open.

Changing and Adjusting the Lamp

The QXL™ 750/77 lamp is remarkably easy to replace. No tools are required and the lamp is accessible from the exterior of the head. Once the lamp is turned to the unlocked position, power is disconnected from the lamp. Two QXL lamps are available.

Part Number	Lamp Code	Watts	Volts	Lumens	Color Temp.	Average Rated Life	Application
RT174	QXL 750//77	750	77	22,950	3250°K	300 hours	High Output/ Professional Stage
RT175	QXL 750/77X	750	77	18,000	3050°K	1500 hours	Long Life/Reduced Output



WARNING: *The QXL lamp gets very hot during operation and remains hot for a time after being dimmed out. To ensure that you do not burn your fingers on the lamp base, always use gloves when removing a lamp from the Source Four Revolution fixture.*



WARNING: *RISK OF ELECTRIC SHOCK! Do not place objects other than a QXL lamp in the Source Four Revolution lamp socket.*



CAUTION: *Do not touch the glass envelope of the QXL lamp. Oils and residue left on the envelope can cause premature failure of the lamp. If the envelope is touched, clean it with rubbing alcohol and a soft cloth before installing the lamp in the fixture.*

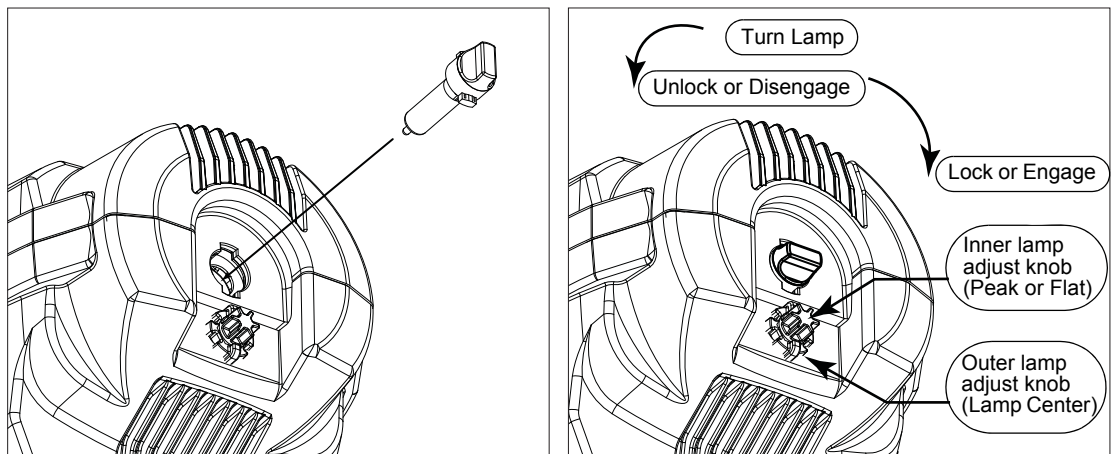

Replacing the QXL lamp:

- Step 1: Power-down the fixture and disconnect the AC input cable. See [Power-down Procedure, page 9](#).
- Step 2: Using gloves, grab the lamp base and turn it 1/4 turn counter-clockwise to disconnect the lamp.
- Step 3: Pull the lamp straight out of the head.
- Step 4: Install the replacement lamp, aligning the tabs in the lamp base with the slots in the socket.
- Step 5: Turn the replacement lamp 1/4 turn clockwise until the lamp is seated and the lamp base appears parallel to the horizontal center-line of the head.

Adjusting the lamp:

- Step 1: Apply power to the fixture and allow it to complete its calibration.
- Step 2: Bring intensity to full and aim the fixture at a flat surface.
- Step 3: Unlock and loosen the outer lamp adjust knob by turning it counter-clockwise.
- Step 4: Gently move the outer lamp adjust knob from side to side and up and down until the lamp is centered in the reflector. The correct positioning puts the brightest spot in the center of the flat surface with equal fall-off toward the edges.
- Step 5: Turn the outer lamp adjust knob clockwise to lock the lamp into position.
- Step 6: Turn the inner lamp adjust knob either direction to achieve an optimum field. Turning to the right (clockwise) creates a flat field, which provides best results for gobos. If you turn it too far, it can create a dark center. Turning to the left (counter-clockwise) creates a peak in the center.

Adjusting Belt Tensions

Over time and with repeated use, belts may loosen. Belts that are too loose may cause the fixture to calibrate incorrectly and may affect the movement or repeatability of the motorized mechanisms. Follow all belt adjustment procedures carefully to insure optimum operation of the Revolution luminaire.

Adjusting Tilt and Pan Tension

Adjusting tilt belt tension:

- Step 1: Power-down the fixture. See [Power-down Procedure, page 9](#).
- Step 2: Using a #2 Philips screwdriver, loosen the four captured screws on the tilt-side yoke cover and remove the cover. The tilt-side has the tilt lock mechanism protruding through the yoke cover.
- Step 3: Loosen, but do not remove, the four screws securing the tilt motor assembly to the yoke leg.
- Step 4: Pinch the tilt belt together a few times to adjust the motor placement. Allow the motor to settle against the spring. Make sure the spring is centered on the plate.
- Step 5: Tighten the motor screws in a star pattern.
- Step 6: Place the yoke cover back on and tighten the captured screws.

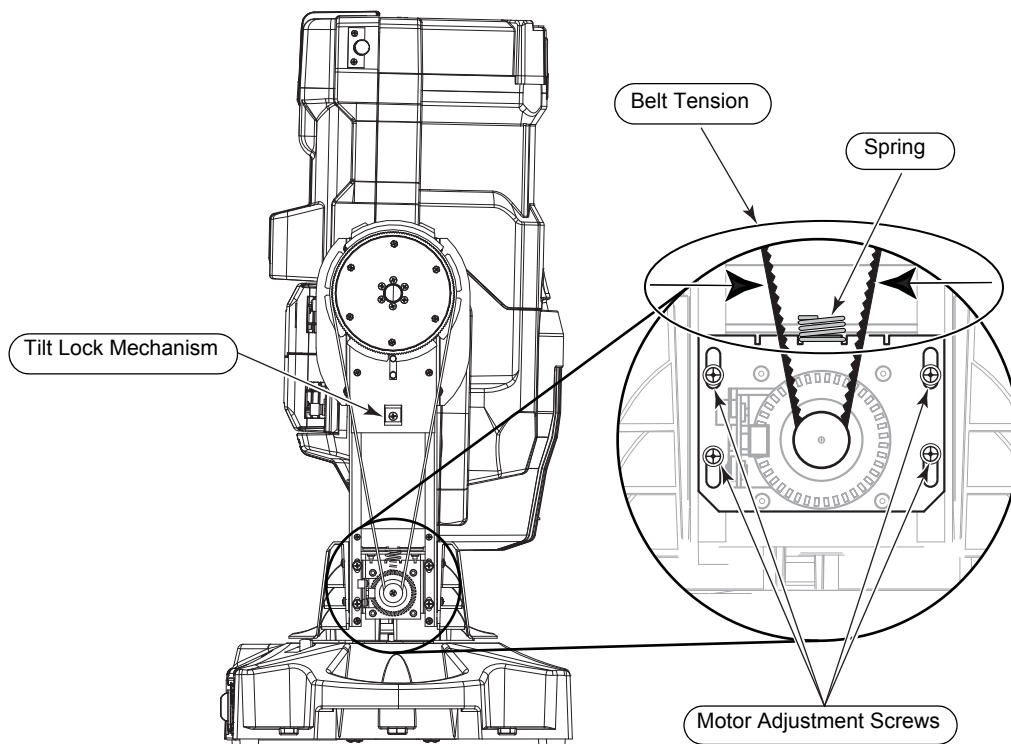

Adjusting pan belt tension:

- Step 1: Power-down the fixture (see [Power-down Procedure, page 9](#)) and disconnect any power and data cables from the upper enclosure.
- Step 2: Place the fixture on its side on a stable surface.
- Step 3: Remove any hook or hanging hardware from the data module side of the upper enclosure and loosen the two rubber feet on that side.
- Step 4: Remove the two screws securing the data module to the upper enclosure and carefully slide the module out of the upper enclosure. Place the module out of the way, keeping all connectors plugged in.
- Step 5: Loosen, but do not remove, the four screws securing the pan motor assembly to the upper enclosure.
- Step 6: Pinch the pan belt together a few times to adjust the motor placement. Allow the motor to settle against the spring. Make sure the spring is centered on the plate.
- Step 7: Tighten the motor screws in a star pattern.
- Step 8: Carefully slide the data module back into the upper enclosure. Ensure that no wires are pinched in the process.
- Step 9: Reinstall and tighten the two screws securing the data module to the upper enclosure.
- Step 10: Retighten the screws securing the rubber feet on the data module side and reinstall any removed hanging hardware or hooks, if necessary.

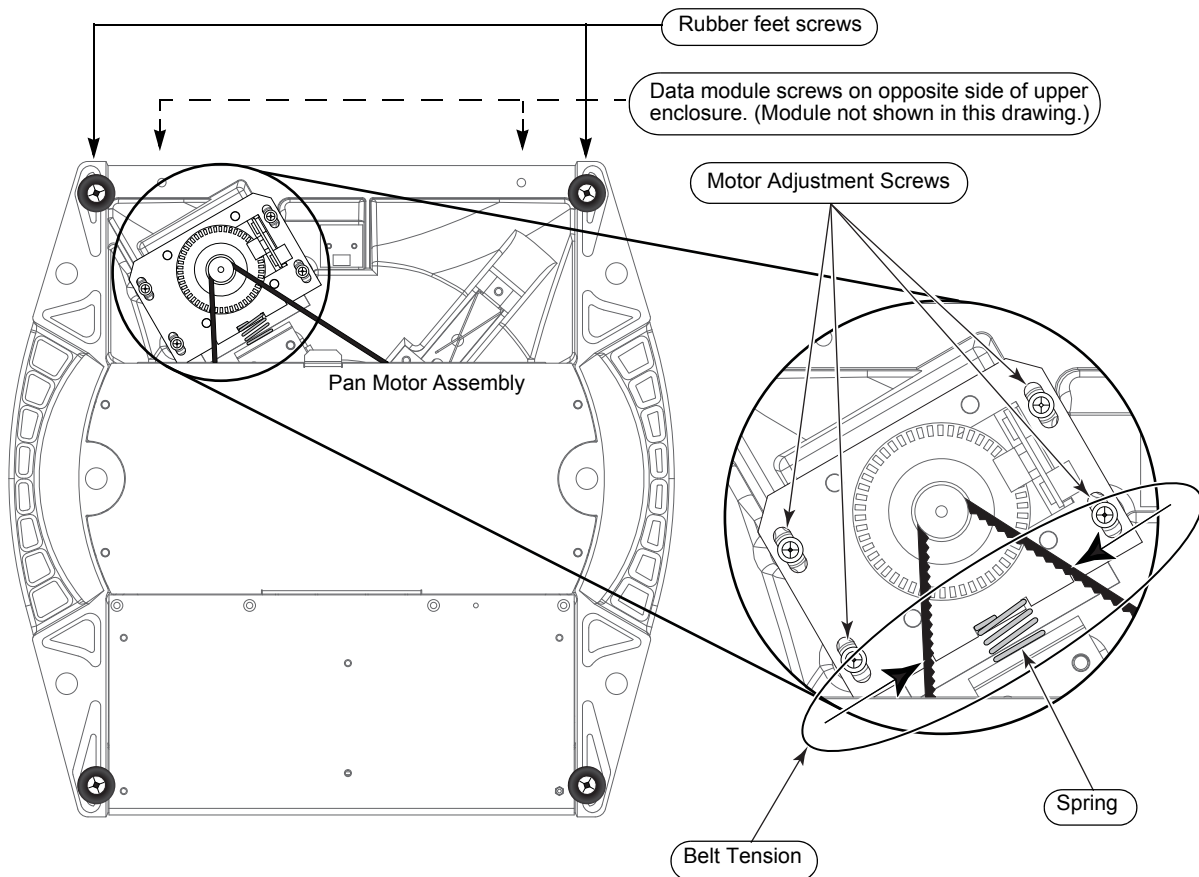

Adjusting the Scroller, Front Lens, and Rear Lens Belts

To access the three belts inside the head, you will need to remove the head cover. Follow the general instructions below before adjusting the belts.

General belt adjustment instructions:

- Step 1: Power-down the fixture. See [Power-down Procedure, page 9](#).
- Step 2: Lock the fixture head and yoke in a convenient position using the pan and tilt locks.
- Step 3: Remove the head cover by loosening, but do not remove, the two captured screws holding it in place and lift the cover off the head.

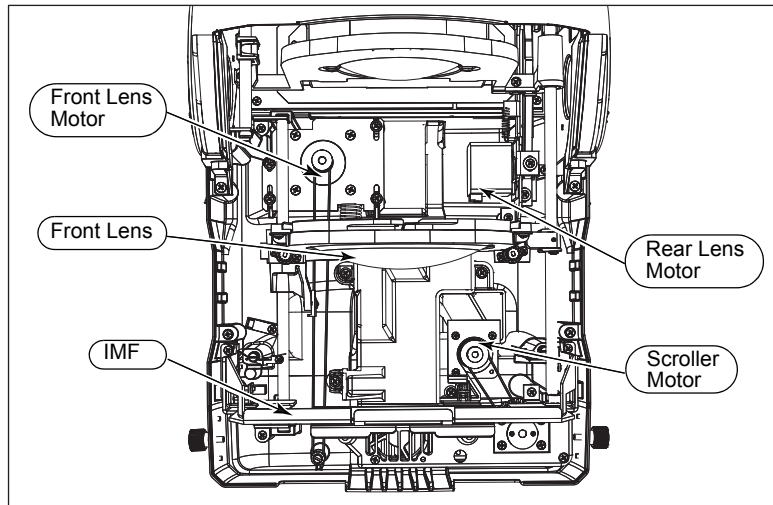

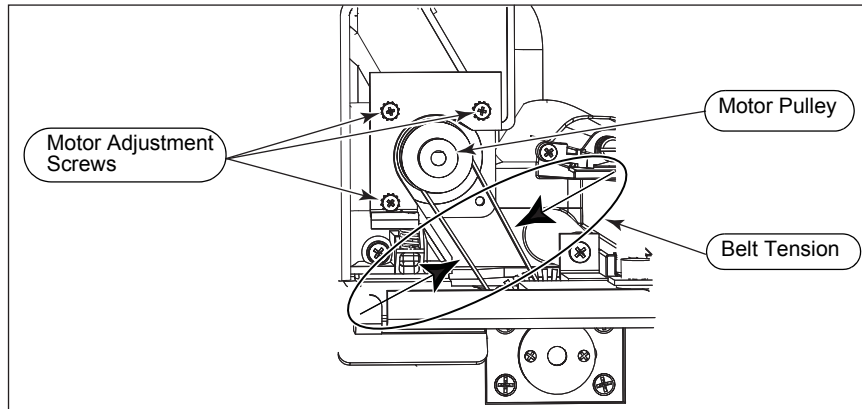

Adjusting the scroller drive belt tension:

- Step 1: See [General belt adjustment instructions](#);, page 34.
- Step 2: Remove the scroller if not already done. See [Removing and replacing the Scroller Cartridge](#);, page 24.
- Step 3: Using both hands, gently fold in the IMF doors and move the assembly toward the rear lens.
- Step 4: Loosen, but do not remove, the three motor mounting plate screws so that the motor moves freely.
- Step 5: Turn the pulley back and forth two or three times and allow the spring to take up the slack in the belt.
- Step 6: Tighten the three screws.
- Step 7: Pinch the belt together to ensure it maintains pressure and rotate the motor pulley to ensure it turns freely.

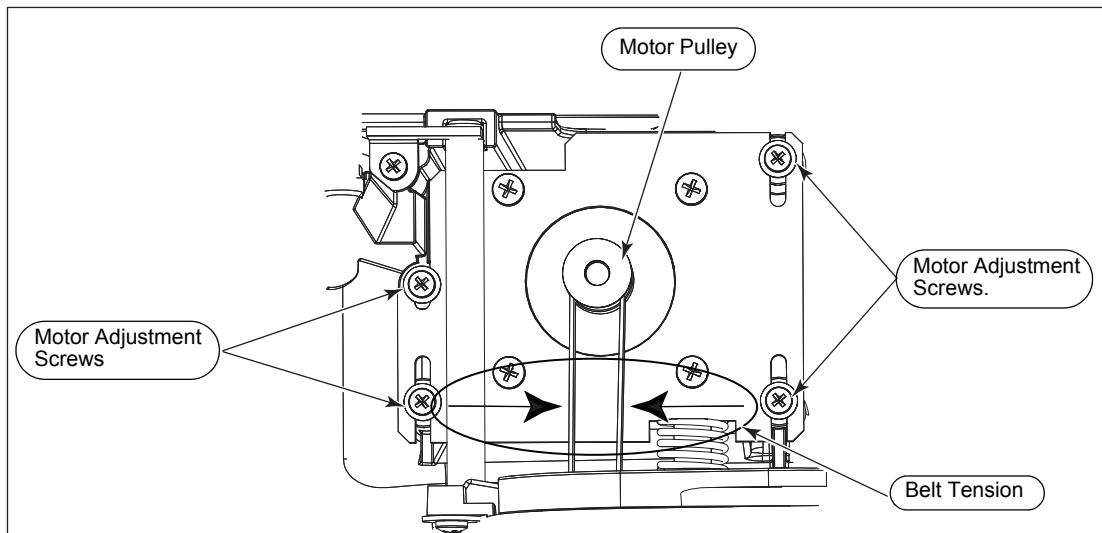

Adjusting the front lens belt:

- Step 1: See [General belt adjustment instructions](#); page 34.
- Step 2: Using both hands, gently move the IMF assembly forward toward the front lens so that you can access the front lens motor.
- Step 3: Using both hands, gently move the rear lens backward so that you can access the motor.
- Step 4: Loosen, but do not remove, the four front lens motor mounting plate screws so the motor moves freely.
- Step 5: Turn the pulley back and forth two or three times and allow the spring to take up the slack in the belt.
- Step 6: Tighten the screws in a star pattern.
- Step 7: Pinch the belt together to ensure it maintains pressure.
- Step 8: Turn the motor by hand counter-clockwise to drive the lens until the IMF closes. There should be a slight resistance. Continue turning to open the IMF.
- Step 9: Turn the motor by hand clockwise to move the lens back. If the IMF does not close properly, readjust the front lens belt so that it is tighter.

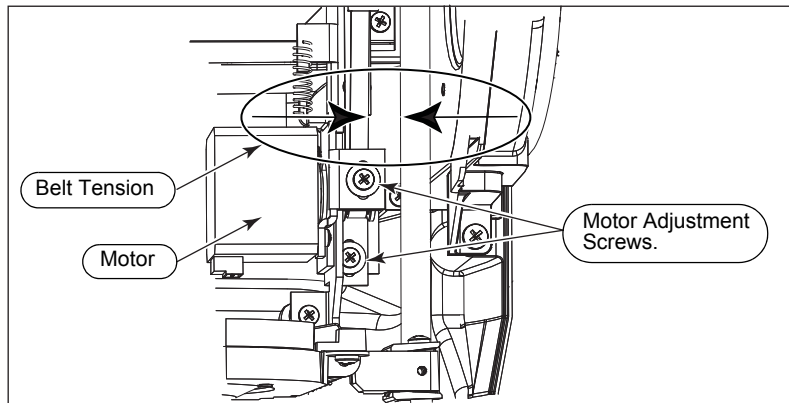

Adjusting rear lens belt:

- Step 1: See [General belt adjustment instructions](#)., page 34.
- Step 2: Using both hands, gently move the IMF assembly forward toward the front lens so that you can access the rear lens motor.
- Step 3: Loosen, but do not remove, the two motor mounting screws so that the motor moves freely.
- Step 4: Move the motor back and forth to allow the spring to take up the slack in the belt.
- Step 5: Tighten the top screw and then the bottom screw.
- Step 6: Gently move the rear lens back and forth with both hands. There should be a slight resistance.

Troubleshooting

LED Indicators

The easiest way to find out the status of your Source Four Revolution fixture is to look at the LED indicators on the upper enclosure. These LEDs are located on the top of the upper enclosure when the fixture is sitting on its base. When the fixture is hung on a pipe, the LEDs are visible to technicians standing below the fixture.

	Green	Amber	Red
Off	No Power	Lamp OK	Calibration Successful
On	Receiving DMX Signal ^{a b}	Lamp Out	Calibration in Progress - or - Error
Blinking (1/second)	Not Receiving DMX Signal		
Fast Blinking (5/second)	Self-Test Mode		

- a) Green and amber blinking together indicates that there is potential software corruption. Recycle power. If this indication persists, contact ETC customer service.
- b) Red and green blinking together indicates that the thumbwheel address is set higher than 481. Reset thumbwheel to 481 or lower. See [Connections and Addressing, page 8](#) for further information.

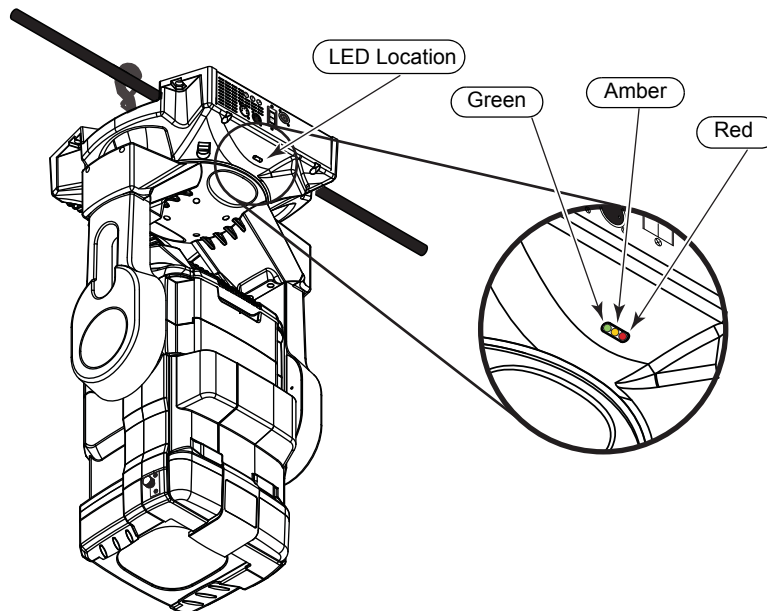

Internal Test Software

The following diagnostic tests are available using the thumbwheels on your Source Four Revolution fixture. To run a test, set the address to the desired test (tests may be run at any time). The green LED will blink rapidly to indicate the fixture is in self-test mode and the fixture will not respond to incoming DMX signal. To return the fixture to DMX operation, set the thumbwheel back to a valid DMX start address.

Test Description	Address			Notes or Test Parameter (#)
HOLD	8	0	0	
All open, Pan & Tilt @ 50%, Intensity @ 75%	8	0	1	
SLOW fade all from 0-100%	8	0	2	20 seconds; continuous cycle.
MED fade all from 0-100%	8	0	3	10 seconds; continuous cycle.
FAST fade all from 0-100%	8	0	4	Bounce; some attributes may not complete their full range of motion.
16 predefined cues run sequentially	8	0	5	5 seconds between cues.
Pan and Tilt motors disabled	8	0	6	NOTE: Cycle power to return to normal operation.
Bypass Calibration	8	0	7	Start-up at this address to skip calibration.
Fade parameters 0-100%, Intensity @	8	0	8	Bounce; some attributes may not complete their full range of motion.
HOLD	8	0	9	
Dimmer (tests 815-819 do not apply)	8	1	#	Use the parameter numbers below in the (#) position of the test address to change the behavior of the tests. Example: test 825 moves the Pan motor from end stop to end stop at a slow speed. Test 826 performs the same movement, but at medium speed. 0 = HOLD 1 = Increment (0-100%) 2 = Decrement (100-0%) 3 = HOLD 4 = Invert (if on, fade to 0, if off, fade to full) 5 = SLOW fade from 0-100%, continuous cycle 6 = MED fade from 0-100%, continuous cycle 7 = FAST fade from 0-100%, continuous cycle 8 = Incremental fade from 0-100% of selected in 10% increments in 1 second timing, continuous cycle 9 = Incremental fade from 0-100% of attribute in 25% increments in 2 second timing, continuous cycle
Pan	8	2	#	
Tilt	8	3	#	
Front Bay (Iris or Wheel modules)	8	4	#	
Rear Bay (Iris or Wheel modules)	8	5	#	
Scroller	8	6	#	
Wheel Function (operates both bays)	8	8	#	
Wheel Index/Rotate (operates both bays)	8	9	#	
Shutter #1 In/Out	9	0	#	
Shutter #1 Rotate	9	1	#	
Shutter #2 In/Out	9	2	#	
Shutter #2 Rotate	9	3	#	
Shutter #3 In/Out	9	4	#	
Shutter #3 Rotate	9	5	#	
Shutter #4 In/Out	9	6	#	
Shutter #4 Rotate	9	7	#	
Rotate All Shutters	9	8	#	
Lenses and Internal Media Frame	8	7	#	

Photometric Data

Minimum Spread

Throw Distance (d)

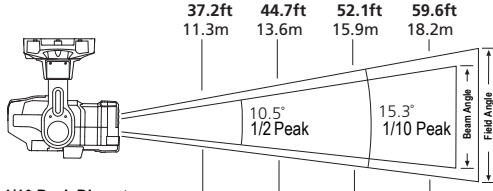

1/10 Peak Diameter	10ft 3.0m	12ft 3.7m	14ft 4.3m	16ft 4.9m
FC	272	188	139	106
LUX	2930	2025	1495	1140

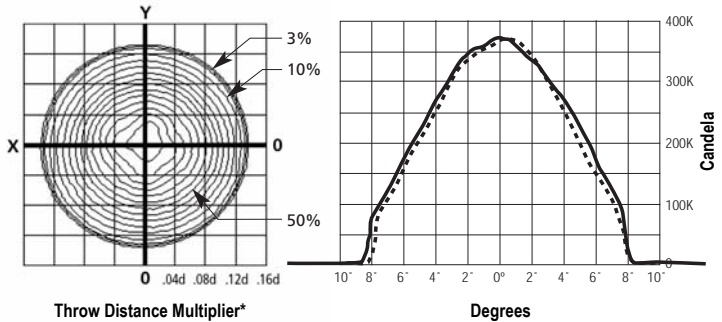

Degree	Candlepower	1/10 Peak Lumens	1/2 Peak Lumens	1/10 Peak Efficiency	LPW
15°	376,520	10,830	7,060	47.19%	14.4

Median Spread

Throw Distance (d)

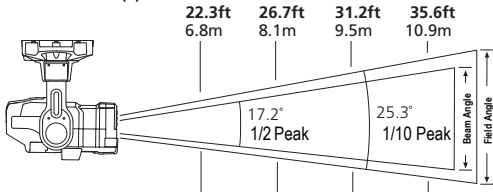

1/10 Peak Diameter	10ft 3.0m	12ft 3.7m	14ft 4.3m	16ft 4.9m
FC	309	216	158	121
LUX	3325	2325	1700	1300

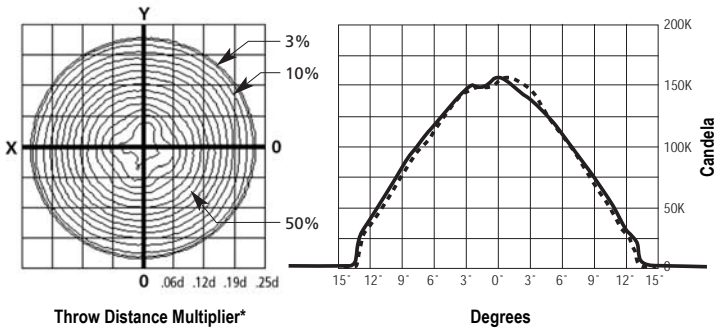

Degree	Candlepower	1/10 Peak Lumens	1/2 Peak Lumens	1/10 Peak Efficiency	LPW
25°	153,730	11,760	7,425	51.24%	15.7

Maximum Spread

Throw Distance (d)

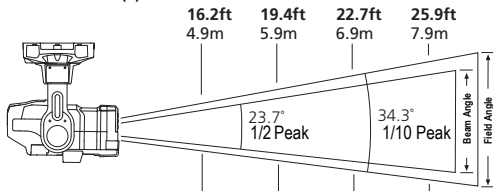

1/10 Peak Diameter	10ft 3.0m	12ft 3.7m	14ft 4.3m	16ft 4.9m
FC	299	208	152	117
LUX	3220	2240	1640	1260

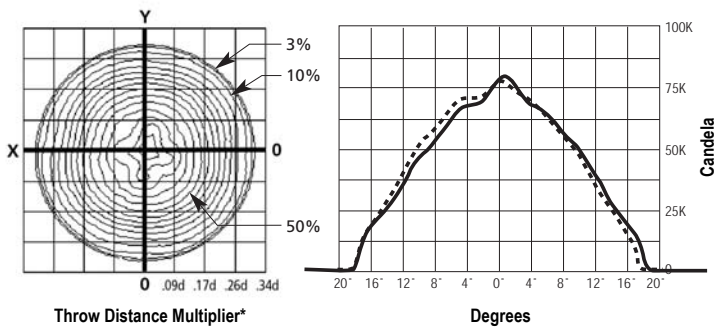

Degree	Candlepower	1/10 Peak Lumens	1/2 Peak Lumens	1/10 Peak Efficiency	LPW
35°	78,410	10,950	6,925	47.71%	14.6

All photometric data in this document was prepared using standard production fixtures, and the Prometric™ CCD measurement system.

Fixtures were adjusted for blending (cosine) distribution, and were tested with a calibrated lamp at its rated voltage. All data was normalized to nominal lamp lumens.

To determine illumination in footcandles or lux at any throw distance, divide candlepower by distance squared.

* (distance from origin) = (throw distance) x (throw distance multiplier)



Corporate Headquarters ■ 3031 Pleasant View Road, P.O. Box 620979, Middleton, Wisconsin 53562-0979 USA ■ Tel +608 831 4116 ■ Fax +608 836 1736
London, UK ■ Unit 26-28, Victoria Industrial Estate, Victoria Road, London W3 6UU, UK ■ Tel +44 (0)20 8896 1000 ■ Fax +44 (0)20 8896 2000
Rome, IT ■ Via Ennio Quirino Visconti, 11, 00193 Rome, Italy ■ Tel +39 (06) 32 111 683 ■ Fax +39 (06) 32 656 990
Holzkirchen, DE ■ Ohmstrasse 3, 83607 Holzkirchen, Germany ■ Tel +49 (80 24) 47 00-0 ■ Fax +49 (80 24) 47 00-3 00
Hong Kong ■ Rm 1801, 18/F, Tower 1 Phase 1, Enterprise Square, 9 Sheung Yuet Road, Kowloon Bay, Kowloon, Hong Kong ■ Tel +852 2799 1220 ■ Fax +852 2799 9325
Service: (Americas) service@etconnect.com ■ (UK) service@etceurope.com ■ (DE) techserv-hoki@etconnect.com ■ (Asia) service@etcasia.com
Web: www.etconnect.com ■ Copyright © 2007 ETC. All Rights Reserved. ■ Product information and specifications subject to change.
7160M1200 ■ Rev E ■ Released 8/2008